

Automatic flush bolt OLDA 26 HZA type 2



Function:

Automatic, single action flush bolt for non-spring-loaded bolting of passive door leaf in double doors.

Features:

OLDA 26 HZA is bolted and unbolted automatically, has a rectangular bolt 10x40 mm and forend width 25 mm.

Is available in two versions, either in electrozinc plated or stainless steel.

Usage:

Recessed into door of steel or aluminium profiles, upper left and lower right, at the edge of passive door leaves.

Installation:

Fitted recessed at the edge of the door, either flush with cut-out or without cut-out for the forend.

Fixed with two countersunk 4.8 x 25 mm screws.

Accessories:

Lock plate LP 20 is fastened with two countersunk 4.8 x 25 mm screws.

Strike plate SP 20 is fastened with two countersunk 4.2 x 25 mm screws.

Specification:

- Automatic, single action and non-spring-loaded bolt function
- Rectangular bolt:
 - depth:
 - 40 mm – dormant
 - 44 mm – activated
 - width: 10 mm
 - projection: max 23 mm
 - adjustability: 0 mm
- Round electrozinc plated steel forend
- Product:
 - width: 25 mm
 - height incl. forend: 78 mm
 - depth incl. forend: 87.5 mm
 - forend thickness: 2.5 mm
- Material: steel
- Coating: electrozinc plating
- *Also available in stainless steel*

Service:

Function & system tests are recommended once or twice a year. Test, lubricate and adjust moving parts as needed.

In harsh environments or high frequent use should tests be made more often.

Warranty:

All mechanical “OLDA” branded products have a 36-month factory warranty

Automatic flush bolt OLDA 26 HZA type 2

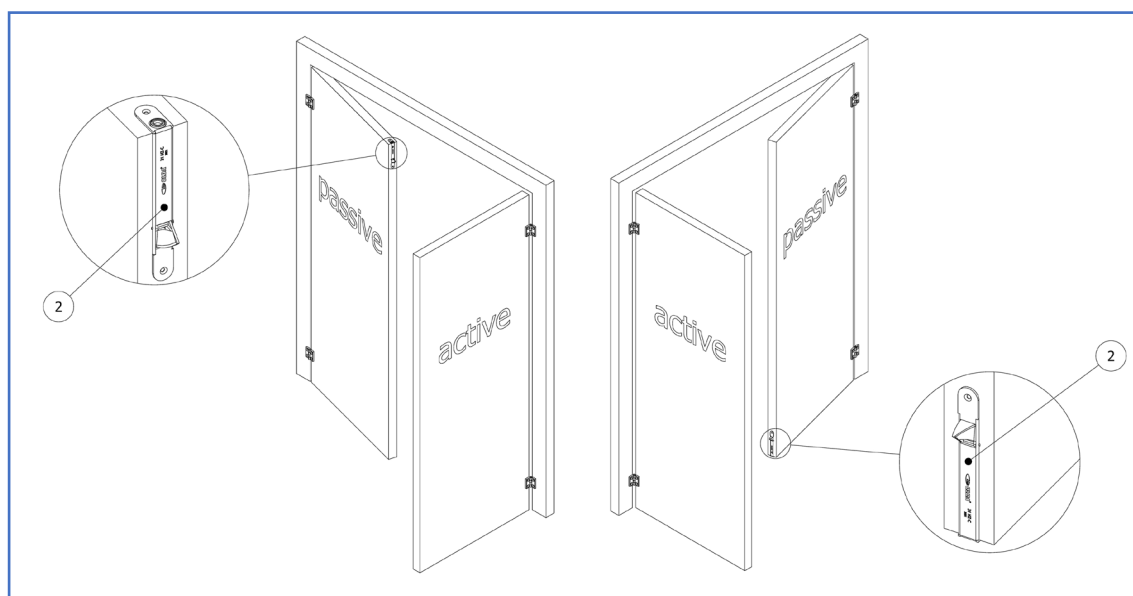
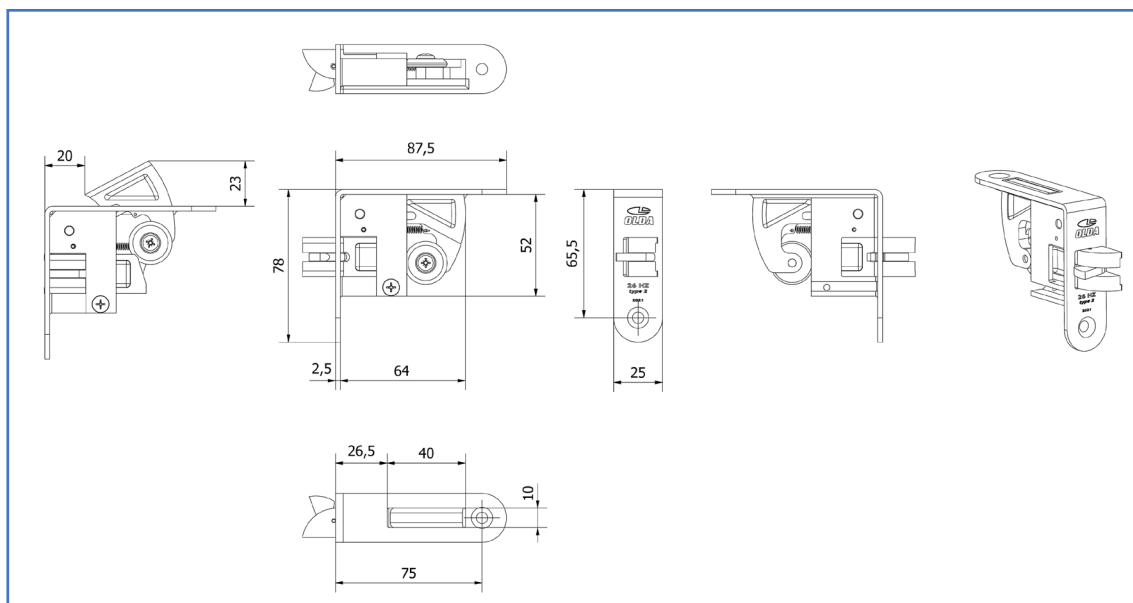

Product documents:

- [Dimensions](#)
- [Installation with forend cut-out](#)
- [Installation without forend cut-out](#)

Product views – 2D:

- [PDF](#)
- [DXF](#)
- [DWG](#)

Product models – 3D:

- [STEP](#)
- [DWG](#)
- [PDF – 3D](#)

OLDA product links:

- [Automatic flush bolt 26 HZA](#)
- [Flush bolt accessories](#)
- [OLDA flush bolt guide](#)
- [OLDA fittings school](#)